

Mechanical Scanner of Vertebral

Keywords: vertebral, 3D model, scoliosis, Cobb angle, vertebral scanner

1. Introduction

It is very important to know the geometry of vertebral for diagnosis and treatment of spinal deformation. There is no equipment to reproduce the shape of vertebral except for very expensive EOS systems (reference¹). Patients lie in CT-s, X-ray images from two sides are not exact enough. The world-wide used Spinal Mouse (reference²) measures only the curve of vertebral, but there is no information about the torsion. In the neck it is not useable because of the sizes. The aim of the development was an equipment measuring the torsion and useable at the neck.

2. Methods

First version was based on the mobile phone. There is an accelerometer in the phone, and moving the phone the position can be integrated from the acceleration.

2.1 Mobile phone application

The working principle is the same as the Spinal mouse. The phone application integrates the acceleration and store data in its own memory. If it was needed the data can be sent to PC via Bluetooth®. The phone was a Nokia N97 type with Symbian S60v5 operating system. Programming language was Python and program needs 3.5 Mbyte free memory (reference³). The program calculates positions of vertebra sections upon the values of acceleration: Starting the application the program search for Bluetooth connection. It is possible to use it or store data inside and transfer them later. The vertebral can be shown on the phone (Fig 1) as well as the on the PC (Fig 2).

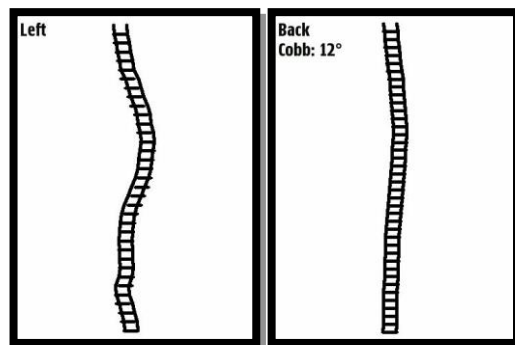

*Figure 1.
Left and Back view of a vertebral*

*Figure 2.
Vertebral data on PC*

The fluent and frictionless driving the equipment is a basic requirement, so with help of an old mouse and a phone console, a new docking equipment was built. (Figure 3)



*Figure 3.
Docking equipment*

Later with help of 3D prototyping a new docking equipment was developed (Figure 4).



*Figure 4:
3D printed docking equipment*

2.2 Cobb angle

In case of C-shape scoliosis the maximum and minimum of angles on the back-view can be defined and cobb angle is defined. In case of S-shape scoliosis, the program search for inflexion point if any. After the upon 3 point the two cobb angles can be calculated numerically (reference⁴).

2.3 New version of vertebral scanner

The traditional Spinal Mouse (reference²) measures only the curve position of spine and it is not able to track the torsion of vertebral because of its wheels are arranged as it was a bicycle. It is not able to measure on neck part of spine because of its geometry. Phone based equipment did not solve these problems. We have created a brand new version. The new construction is based on an MMA 3D accelerator sensor (Figure 5.) and an encoder (Figure 6.).

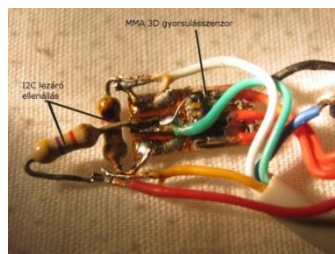

*Figure 5.
The MMA 3D accelerometer*



Figure 6.
The encoder

While the encoder moves along the spine arc length is continuously measured. The accelerator sensor and encoder built on a printed circuit board (PCB). Data from this equipments are processed a central processing unit (CPU). Mouse is controlled by user so a button is on the PCB. The outer voltage is 5V. The accelerator sensor works on 3.3V so a level interface was needed. We can connect to the PCB trough Inter Integrated Circuit (I²C) bus or program loader connector. Connection to PC-s is solved by USB interface. The PCB is shown on Figure 7. and the scheme is on the Figure 8.

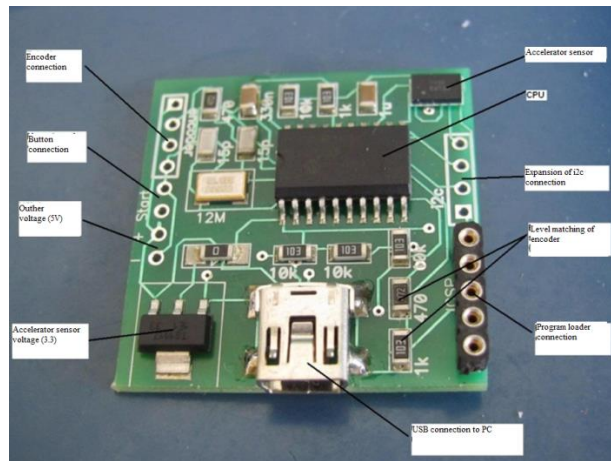

Figure 7.
The electronics

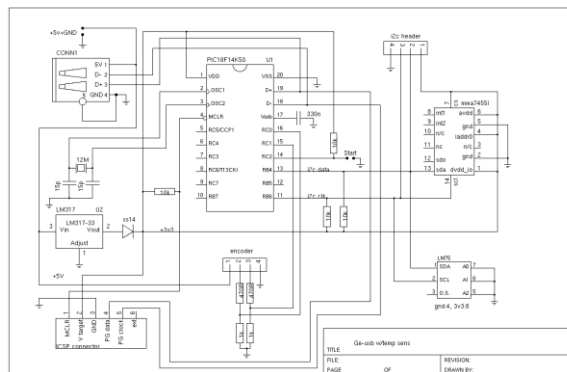

Figure 8.
The scheme of electronics

There are two supporting wheel to measure the rotation. The encoder built in the instrument such a way that the mouse can follow even the curvature of neck. (Figure 9).

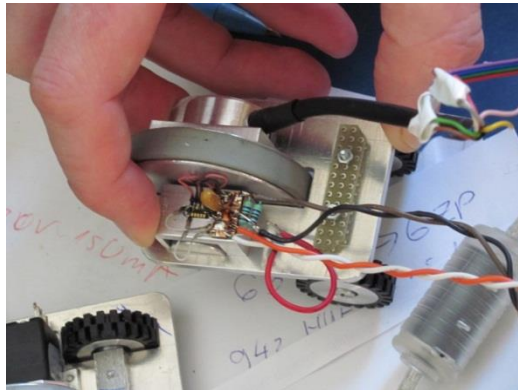

Figure 9.

The supporting wheels

A rapid prototyped aesthetic housing was manufactured (Figure 10).

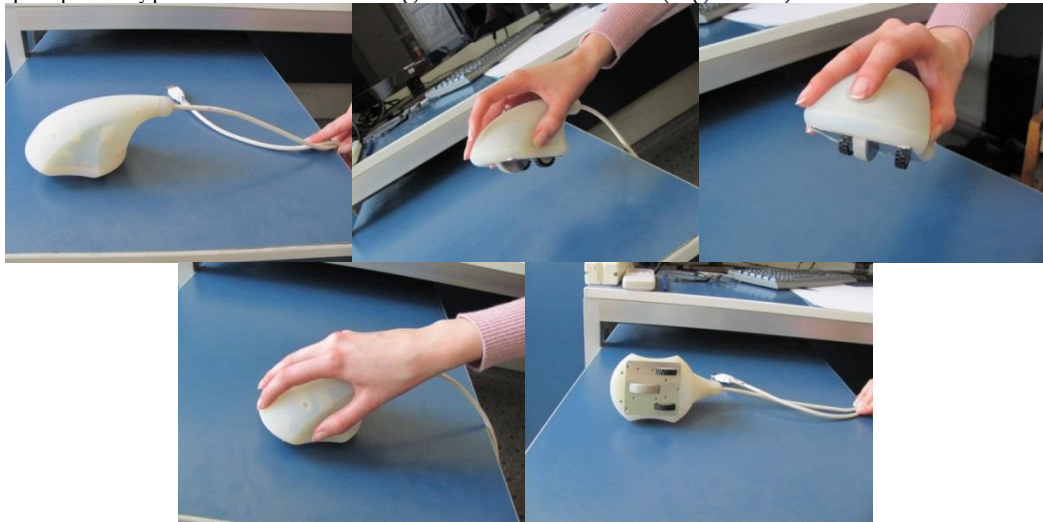

Figure 10.

The product

2.4 Mathematical background of measuring

Direction is acceleration is registered in the coordinate (x, y, z) system of PCB (Figure 11). Z axe of global coordinate system points to centrum of Earth. X and Y axes are in the perpendicular plane. The gravity vector measured in (x, y, z) system is (g_x, g_y, g_z) . The encoder gives the movement Δs in direction z (Figure 11).

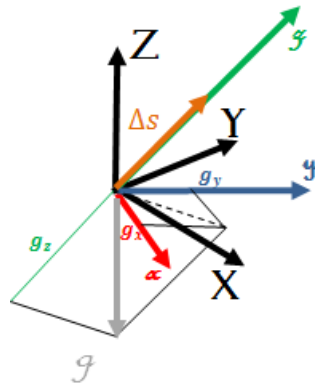

Figure 11.
The gravity vector defines the global coordinate system

When the momentary g vector in the i . moment is measured there is an average computing because the sensitivity of the instrument (1).

(1)

The unit vector point to direction of gravity at the i . moment:

(2)

The resultant movement is the sum of movements of the i . moments (reference⁵)

(3)

The equations of curve

(4)

Frenet frame of curve is defined by tangent curvature and torsion directions (reference⁶). We have measured Δs movement, so the curve parameterized by curve length. The tangent unit vector is:

(5)

The normal unit vector is

(6)

and the binormal unit vector is

(7)

The Figure 12. shows the directions of Frenet frame vectors.

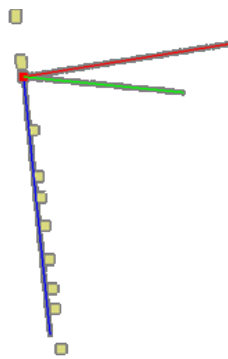

Figure 12.
The Frenet frame

3. Model of vertebral

The curve and the direction of curvature define the situation of vertebra and it shown on Figure 13.

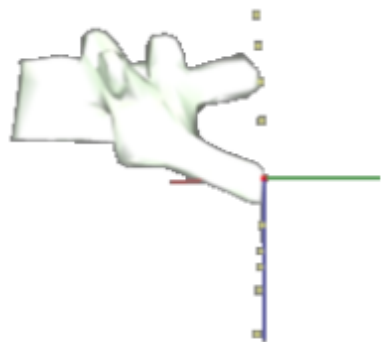

Figure 13.
Position of vertebra

Because the encoder gives the curve length, from (4) we can compute the coordinates and derivatives of $g(s)$ curve. We know the lengths at s_i points. The reparameterization (8) helps to define the correct positions of vertebrae.

(8)

We suppose that the vertebrae divide the length upon the original model (reference⁷). The reconstructed model is shown on Figure 14.



Figure 14.
Model of vertebral

4. Results

For every coordinate function (9), (10) and (11) we can write equations like for x:-

We can compute the curvature (g) and torsion of curve (c) substituted (9), (10) and (11) into (12) and (13).

(12)

and

(13)

